

plantlogic

innovative products
for smart growers



30 Liter Drainage Collection Pot

Ideal for substrate production

Long Legs (5.5-8.5 cm/2.2-3.3")

- Prevents root contact with soil.
- Prevents contact with pathogens.
- Improves drainage and root zone health.

100% Drainage Collection

- Control humidity within tunnels.
- Excellent oxygen uptake.
- Cost effective system design.
- Avoid environmental impact of drainage.

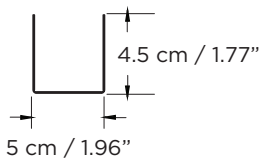
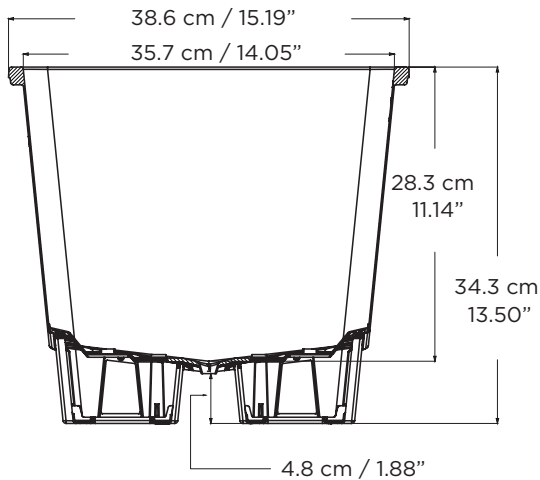

Plastic gutter **Item #1300010**



7.9 Gallons
Item #1307133

Excellent Drainage & Root Ventilation

- 7 center holes drain into inexpensive gutter.
- 26 side holes allow oxygen uptake to prevent anaerobic conditions.
- Wide legs are stable even on soft ground.

Unique Stacking Design

Allows for compact stacking minimizing shipping cost.

- 27,456* pots per 20' container.
- 58,080* pots per 40' container.
- 67,122* pots per 40' HQ.

*Approximate pot quantity per container.

Top down

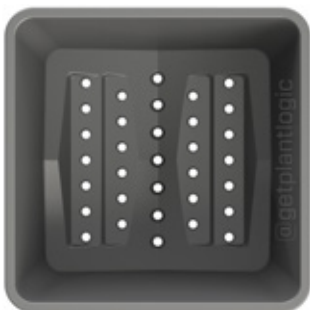

Pot side

Holes on angled bottom provide oxygen to roots

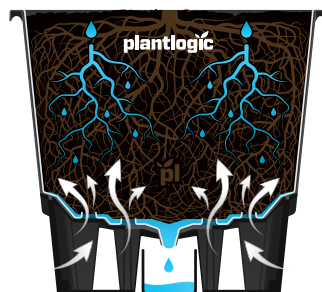

Center holes collect all drainage

Pot bottom

Drainage Through center holes

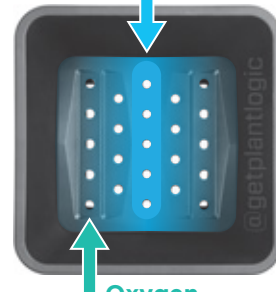

Oxygen Through outer holes